

H•NBJ16

小徑精搪孔刀 Small Diameter Boring System

精搪孔刀本體 Body
精搪孔刀桿 Cutting Bar

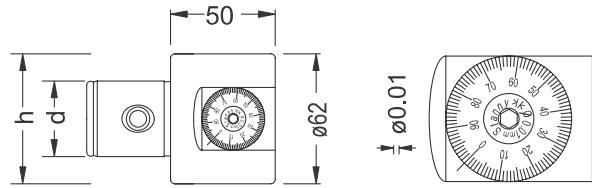

精搪孔刀本體
Body

微調尺寸刻劃環
Adjust the Graduation

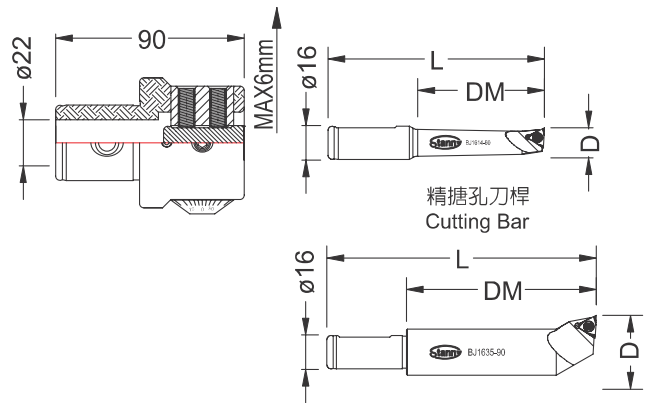

精搪孔刀桿
Cutting Bar

H•NBJ16 小徑精搪孔刀—精搪孔刀本體 Body for H•NBJ16 Boring System

| 訂貨編號 Order No. | 規格 Model | h | d | 行程 Front | 刀徑 Cutting Bar | 板手 Wrench | 淨重 N.W. |
|-------------------|-------------|----|----|-------------|-------------------|--------------|------------|
| 16300050 | HNBJ16 | 63 | 36 | 6 | $\phi 16$ | $\square 4$ | 1.20 |

H•NBJ16 小徑精搪孔刀—精搪孔刀桿 Cutting Bar for H•NBJ16 Boring System

| 訂貨編號 Order No. | 規格 Model | 範圍 D Boring Range $\phi D_{min}-\phi D_{max}$ | 深度 DM | L | 系統 System | 刀片 Insert | 螺絲 Bolt | 板手 Wrench | 淨重 N.W. | | |
|-------------------|-------------|---|----------|-----|--------------|--------------|-------------|--------------|------------|------|------|
| 16010624 | BJ1606-24 | 6-9 | 24 | 73 | HNBJ16 | WBG0601..L | SB-1STR-M2 | T6 | 0.08 | | |
| 16010832 | BJ1608-32 | 8-11 | 32 | 80 | | TBGT0601..L | | | 0.08 | | |
| 16011040 | BJ1610-40 | 10-13 | 40 | 87 | | | | | 0.08 | | |
| 16011253 | BJ1612-53 | 12-15 | 53 | 98 | | TPGH0902..L | SB-2TR-M2.5 | | T8 | 0.10 | |
| 16011460 | BJ1614-60 | 14-17 | 60 | 103 | | | | | | | 0.10 |
| 16011668 | BJ1616-68 | 16-21 | 68 | 110 | | | | | | | 0.12 |
| 16012083 | BJ1620-83 | 20-26 | 83 | 125 | | TPGH1103..L | | SB-3TR-M3 | T8 | 0.20 | |
| 16012590 | BJ1625-90 | 25-31 | 90 | 128 | | | | | | | 0.30 |
| 16013090 | BJ1630-90 | 30-36 | 90 | 128 | | | | | | | 0.32 |
| 16013590 | BJ1635-90 | 35-41 | 90 | 128 | | | | | | 0.32 | |
| 16014090 | BJ1640-90 | 40-46 | 90 | 128 | | | | | | 0.38 | |
| 16014590 | BJ1645-90 | 45-51 | 90 | 128 | | | | | | 0.38 | |



H·NBJ16

小徑精搪孔系統 Small Diameter Boring System

整組 SET $\phi 6 \sim \phi 51$



| 訂貨編號 Order No. | 規格 Model | 範圍 D Boring Range $\phi D_{Min} - \phi D_{Max}$ | 組合系統-主軸柄規格 Taper Shank | L1 | 淨重 N.W |
|-------------------|--------------|---|----------------------------|----|-----------|
| 16910410 | NT40-HNBJ16 | 6-51 | H63 DIN2080 ISO40-H63-55 | 55 | 9.3 |
| 16910510 | NT50-HNBJ16 | 6-51 | H63 DIN2080 ISO50-H63-65 | 65 | 11.2 |
| 16911410 | BT40-HNBJ16 | 6-51 | H63 MAS403 BT40-H63-55 | 55 | 9.1 |
| 16911510 | BT50-HNBJ16 | 6-51 | H63 MAS403 BT50-H63-65 | 65 | 11.7 |
| 16911512 | BT50-HNBJ16 | 6-51 | H63 MAS403 BT50-H63-85 | 85 | 12.2 |
| 16912410 | SK40-HNBJ16 | 6-51 | H63 DIN69871A ISO40-H63-60 | 60 | 9.1 |
| 16912510 | SK50-HNBJ16 | 6-51 | H63 DIN69871A ISO50-H63-65 | 65 | 10.9 |
| 16914610 | HSK63-HNBJ16 | 6-51 | H63 DIN69893A HSK63-H63-67 | 67 | 9.0 |

| 訂貨編號 Order No. | 搪孔刀桿 Cutting Bar | 範圍 D Boring Range $\phi D_{Min} - \phi D_{Max}$ | 深度 DM | 刀片 Insert | 螺絲 Bolt | 板手 Wrench | 淨重 N.W | | | |
|-------------------|---------------------|---|----------|--------------|-------------|--------------|-----------|--|--|------|
| 16010624 | BJ1606-24 | 6-9 | 24 | WBGT0601..L | SB-1STR-M2 | T6 | 0.08 | | | |
| 16010832 | BJ1608-32 | 8-11 | 32 | TBGT0601..L | | | 0.08 | | | |
| 16011040 | BJ1610-40 | 10-13 | 40 | | | | 0.08 | | | |
| 16011253 | BJ1612-53 | 12-15 | 53 | TPGH0902..L | SB-2TR-M2.5 | T8 | 0.10 | | | |
| 16011460 | BJ1614-60 | 14-17 | 60 | | | | 0.10 | | | |
| 16011668 | BJ1616-68 | 16-21 | 68 | | | | 0.12 | | | |
| 16012083 | BJ1620-83 | 20-26 | 83 | TPGH1103..L | SB-3TR-M3 | T8 | 0.20 | | | |
| 16012590 | BJ1625-90 | 25-31 | 90 | | | | 0.30 | | | |
| 16013090 | BJ1630-90 | 30-36 | 90 | | | | 0.32 | | | |
| 16013590 | BJ1635-90 | 35-41 | 90 | | | | 0.32 | | | |
| 16014090 | BJ1640-90 | 40-46 | 90 | | | | 0.38 | | | |
| 16014590 | BJ1645-90 | 45-51 | 90 | | | | | | | 0.38 |
| | | | | | | | | | | 0.38 |

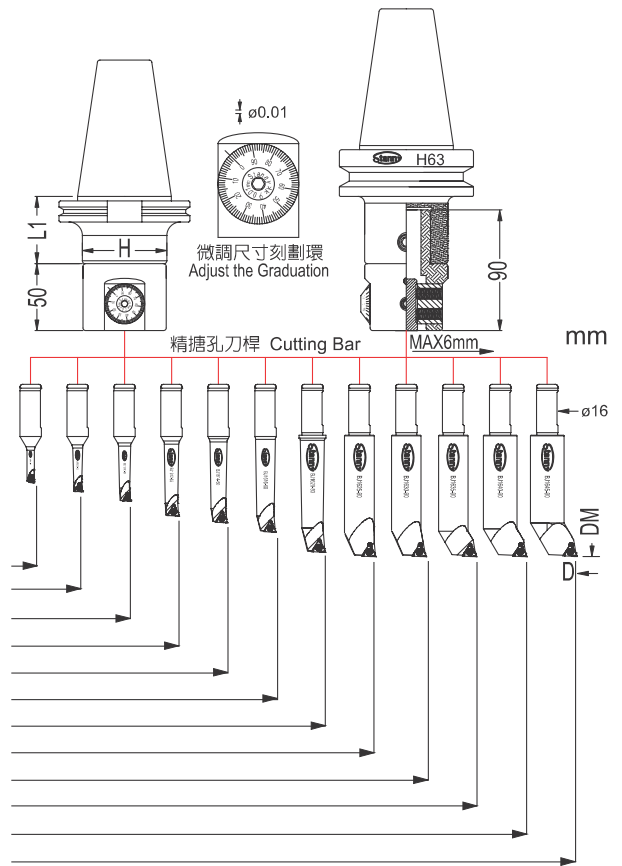

H•NBJ16

小徑精搪孔系統 Small Diameter Boring System

BM1625 精搪孔刀桿 BM1625 Cutting Bar $\phi 29 \sim \phi 68$

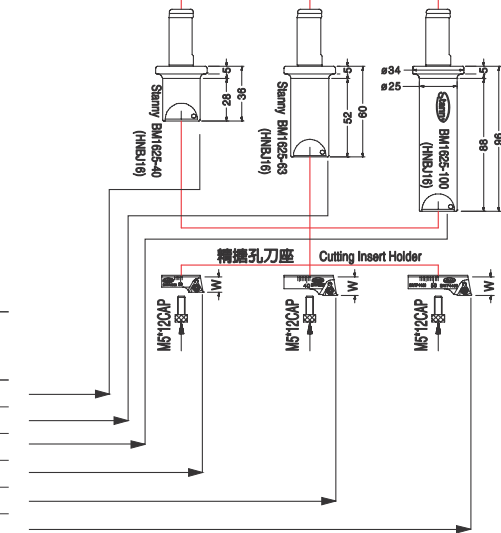
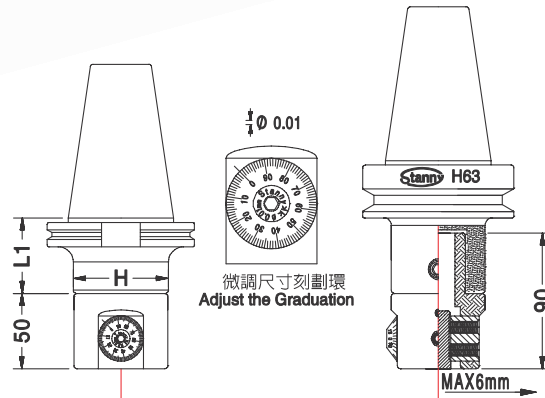

| 訂貨編號 Order No. | 規格 Model | 範圍 D Boring Range $\phi D_{min} \sim \phi D_{max}$ | W | 淨重 N.W. |
|-------------------|-------------|--|----|------------|
| 16025040 | BM1625-40 | | 28 | 0.20 |
| 16025063 | BM1625-63 | | 52 | 0.29 |
| 16025100 | BM1625-100 | | 88 | 0.43 |
| 50252938 | SRTP2938 | 29-38 | 10 | 0.01 |
| 50323652 | SRTP3652 | 36-52 | 12 | 0.02 |
| 50404468 | SRTP4468 | 44-68 | 12 | 0.03 |